

# Fortinet

## NSE7\_OTIS-7.2 Exam

Fortinet NSE 7 - OT Security 7.2



**Thank you for Downloading NSE7\_OTIS-7.2 exam PDF Demo**

You can Buy Latest NSE7\_OTIS-7.2 Full Version Download

[https://www.certkillers.net/Exam/NSE7\\_OTIS-7.2](https://www.certkillers.net/Exam/NSE7_OTIS-7.2)

# Version: 6.0

---

## Question: 1

---

What are two benefits of a Nozomi integration with FortiNAC? (Choose two.)

- A. Enhanced point of connection details
- B. Direct VLAN assignment
- C. Adapter consolidation for multi-adapter hosts
- D. Importation and classification of hosts

---

**Answer: C, D**

---

Explanation:

The two benefits of a Nozomi integration with FortiNAC are enhanced point of connection details and importation and classification of hosts. Enhanced point of connection details allows for the identification and separation of traffic from multiple points of connection, such as Wi-Fi, wired, cellular, and VPN. Importation and classification of hosts allows for the automated importing and classification of host and device information into FortiNAC. This allows for better visibility and control of the network.

---

## Question: 2

---

Which three criteria can a FortiGate device use to look for a matching firewall policy to process traffic? (Choose three.)

- A. Services defined in the firewall policy.
- B. Source defined as internet services in the firewall policy
- C. Lowest to highest policy ID number
- D. Destination defined as internet services in the firewall policy
- E. Highest to lowest priority defined in the firewall policy

---

**Answer: ADE**

---

Explanation:

The three criteria that a FortiGate device can use to look for a matching firewall policy to process traffic are:

- A) Services defined in the firewall policy - FortiGate devices can match firewall policies based on the services defined in the policy, such as HTTP, FTP, or DNS.
- D) Destination defined as internet services in the firewall policy - FortiGate devices can also match firewall policies based on the destination of the traffic, including destination IP address, interface, or

internet services.

E) Highest to lowest priority defined in the firewall policy - FortiGate devices can prioritize firewall policies based on the priority defined in the policy. The device will process traffic against the policy with the highest priority first and move down the list until it finds a matching policy.

Reference:

Fortinet NSE 7 - Enterprise Firewall 6.4 Study Guide, Chapter 4: Policy Implementation, page 4-18.

---

### Question: 3

---

Refer to the exhibit and analyze the output.

```
[PH_DEV_MON_NET_INTF_UTIL] : [eventSeverity] =PHL_INFO, [filename] =phPerfJob.cpp,
[lineNumber] =6646, [intfName]= Intel [R] PRO_100 MT Network
Connection, [intfAlias] =, [hostname] =WIN2K8DC, [hostIpAddr] = 192.168.69.6,
[pollIntv] =56, [recvBytes64] =
44273, [recvBitsPerSec] = 6324.714286, [inIntfUtil] = 0.000632, [sentBytes64] =
82014, [sentBitsPerSec] = 1171
6.285714, [outIntfUtil] = 0.001172, [recvPkts64] = 449, [sentPkts64] = 255,
[inIntfPktErr] = 0, [inIntfPktErrPct] = 0.000000, [outIntfPktErr] =0,
[outIntfPktErrPct] = 0.000000, [inIntfPktDiscarded] =0, [inIntfPktDiscardedPct] =
```

Which statement about the output is true?

- A. This is a sample of a FortiAnalyzer system interface event log.
- B. This is a sample of an SNMP temperature control event log.
- C. This is a sample of a PAM event type.
- D. This is a sample of FortiGate interface statistics.

---

**Answer: C**

---

Explanation:

---

### Question: 4

---

Which three Fortinet products can be used for device identification in an OT industrial control system (ICS)? (Choose three.)

- A. FortiNAC
- B. FortiManager
- C. FortiAnalyzer
- D. FortiSIEM
- E. FortiGate

---

**Answer: ADE**

---

Explanation:

- A) FortiNAC - FortiNAC is a network access control solution that provides visibility and control over network devices. It can identify devices, enforce access policies, and automate threat response.
- D) FortiSIEM - FortiSIEM is a security information and event management solution that can collect and analyze data from multiple sources, including network devices and servers. It can help identify

potential security threats, as well as monitor compliance with security policies and regulations.

E) FortiAnalyzer - FortiAnalyzer is a central logging and reporting solution that collects and analyzes data from multiple sources, including FortiNAC and FortiSIEM. It can provide insights into network activity and help identify anomalies or security threats.

Reference:

Fortinet NSE 7 - OT Security 6.4 Study Guide, Chapter 4: OT Security Devices, page 4-20.

---

**Question: 5**

---

Refer to the exhibit

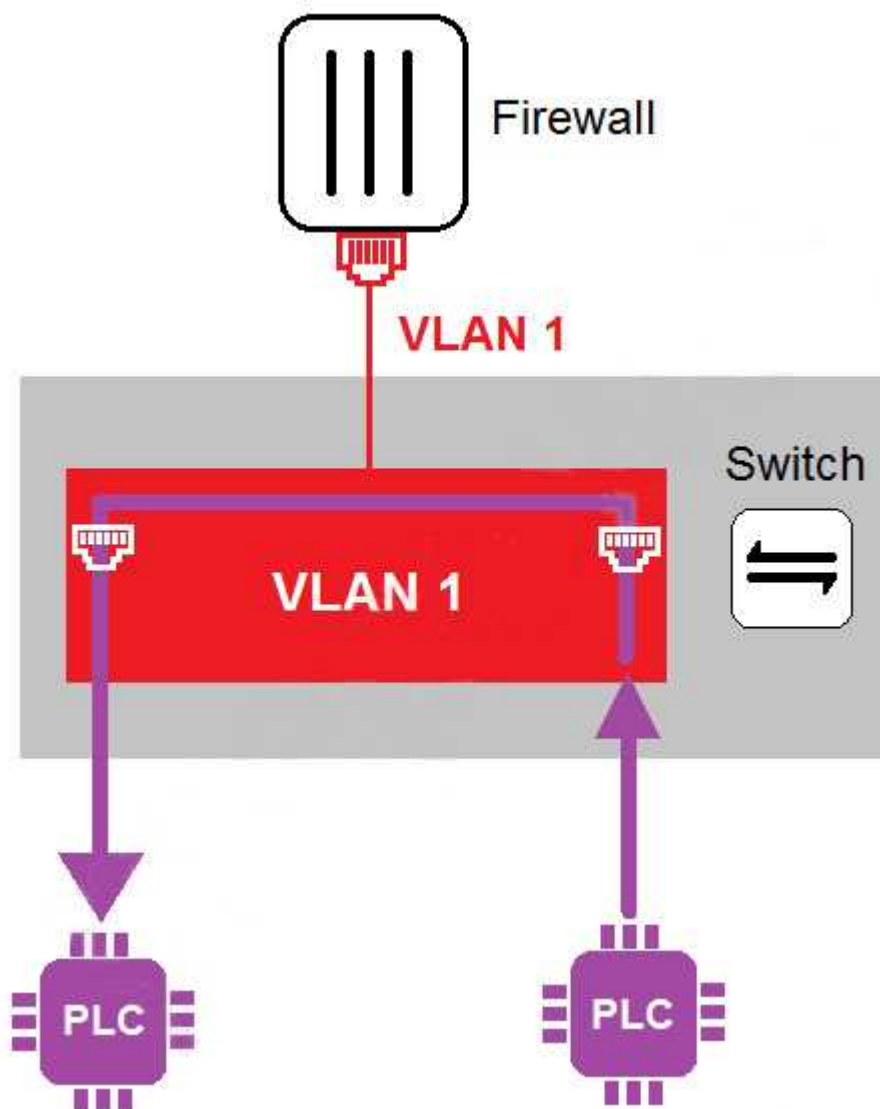

In the topology shown in the exhibit, both PLCs can communicate directly with each other, without going through the firewall.

Which statement about the topology is true?

- A. PLCs use IEEE802.1Q protocol to communicate each other.
- B. An administrator can create firewall policies in the switch to secure between PLCs.

- C. This integration solution expands VLAN capabilities from Layer 2 to Layer 3.
- D. There is no micro-segmentation in this topology.

---

**Answer: D**

---

Explanation:

**Thank You for trying NSE7\_OTIS-7.2 PDF Demo**

**To try our NSE7\_OTIS-7.2 Full Version Download visit link below**

[https://www.certkillers.net/Exam/NSE7\\_OTIS-7.2](https://www.certkillers.net/Exam/NSE7_OTIS-7.2)

## **Start Your NSE7\_OTIS-7.2 Preparation**

Use Coupon “**CKNET**” for Further discount on the purchase of Full Version Download. Test your NSE7\_OTIS-7.2 preparation actual exam with questions.