



Cisco

200-601 Exam

Cisco Managing Industrial Networks for Manufacturing with Cisco Technologies Exam

Thank you for Downloading 200-601 exam PDF Demo

You can Buy Latest 200-601 Full Version Download

<https://www.certkillers.net/Exam/200-601>

<https://www.certkillers.net>

Version: 9.0

Question: 1

Given the CIA triad elements, which ensures first that the data is encrypted and secure, second that the data is trustworthy, and third that the data is accessible by those who need it?

- A. CIA
- B. ICA
- C. ACI
- D. CAI

Answer: A

Question: 2

Refer to the exhibit. The Robot Cell is in a bottling plant. This cell environment needs to consider high flex, EMI, and possible exposure to moisture. Which physical media components need to be considered to prevent network degradation or interruptions?

Location	From	To	Distance (meters)	Environmental Factors	Connector/s	Stranded/Solid Jacket	Shielded
Robot Cell	I/O Block	Robot	20	M311C2, E3 (High Flex, EMI)			

- A. Stranded, shielded wire with an industrial jacket and M12 connectors
- B. Solid, unshielded commercial jacket wire, and M12 connectors
- C. Stranded, unshielded wire with an industrial jacket, and commercial grade RJ45 connectors
- D. Solid, shielded wire with commercial grade jacket, and commercial grade RJ45 connectors

Answer: A

Question: 3

Refer to the exhibit. Which three elements would enable high availability and predictable performance for a motion control application spread across two switches (with video and I/O traffic)? (Choose three)

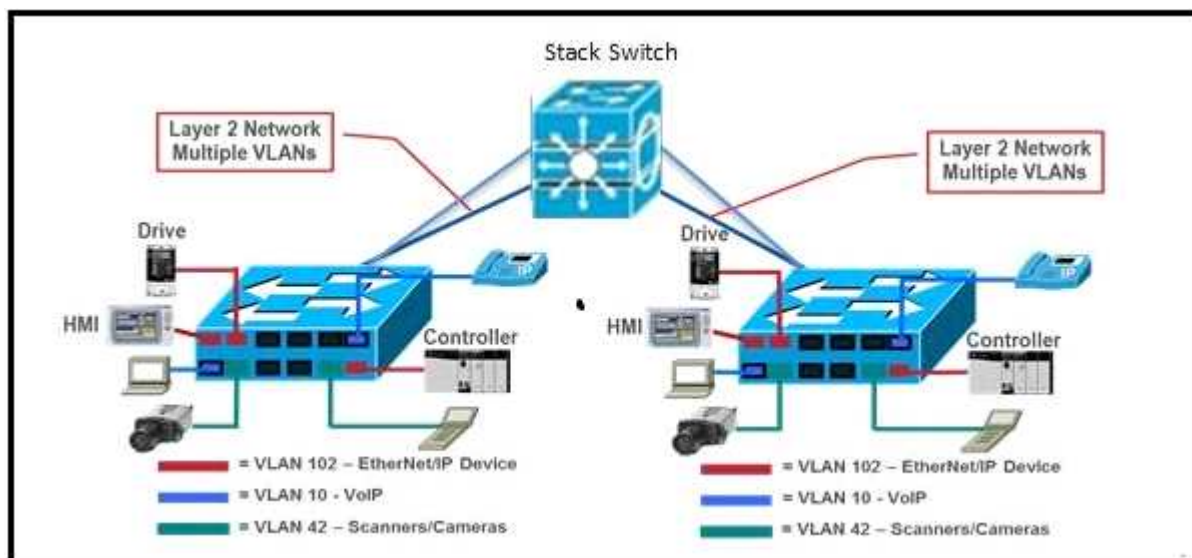

- A. Configure QoS to give PTP traffic the highest priority
- B. Fiber optic uplinks
- C. Redundant uplinks
- D. Configure QoS to give I/O traffic the highest priority
- E. Copper uplinks
- F. Interconnect the two switches

Answer: A, B, C

Question: 4

You have been tasked to design an Ethernet network capable of Motion control with cycle times not to exceed 1ms. In order to create a more deterministic network, what characteristic/s should you primarily focus on?

- A: Latency and Jitter
- B: Redundancy and high availability
- C: Explicit and Implicit messaging
- D: This cycle time is not possible on an Ethernet network
- E: Gigabit port speed

Answer: A

Question: 5

Refer to the exhibit.

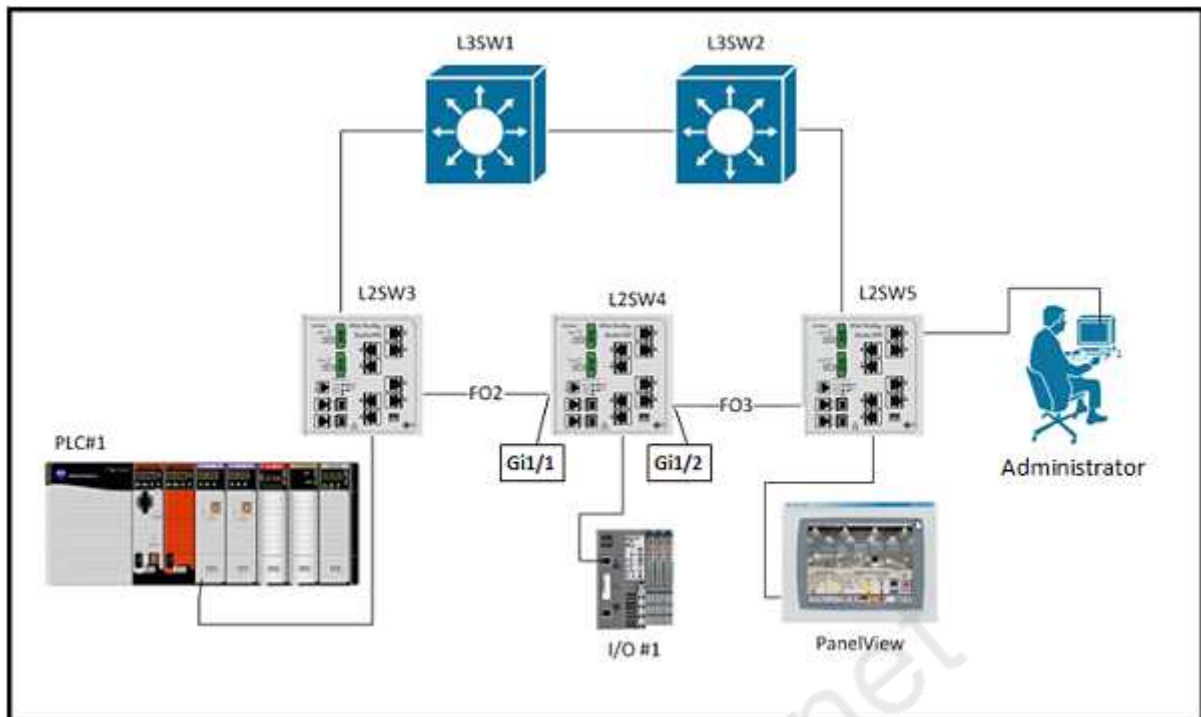

CIP Implicit messages from I/O#1 are being marked IP DSCP 47 by the endpoint and this marking is trusted by L2SW4. L2SW4 is configured to map DSCP 47 to output queue 1 threshold 1. You have received feedback that some of these messages are not being received. Executing the show mls interface GigabitEthernet statistics command on L2SW4 results in:

```
L2SW4# show mls interface GigabitEthernet 1/1 statistics
```

```
<output omitted>
```

```
output queues dropped:
```

queue:	threshold1	threshold2	threshold3
queue 0	0	0	0
queue 1	309232345	450	0
queue 2	300	10	0
queue 3	91	0	0

Repeating this command results in the counters incrementing for queue 1 threshold 1. What are two options for reducing the packet loss on this interface while preserving the end-to-end DSCP marking? (Choose two)

- A. Configure I/O#1 to mark this traffic with a different DSCP that is mapped to a less congested queue
- B. Increase the buffer allocation for input queue 1
- C. Increase the buffer allocation for output queue 1
- D. Alter the service policy to police to a higher CIR
- E. Change the egress queue map on L2SW4 to map this traffic to a less congested queue

Answer: C, E

Question: 6

It is common to use Resilient Ethernet Protocol (REP) on the manufacturing floor as a resiliency protocol, as opposed to the Enterprise where it is not generally deployed. What are two reasons why

REP is more suitable for the plant floor? (Choose two)

- A. REP is only supported on Industrial Ethernet switches, it is not supported on Catalyst switches.
- B. REP converges faster than Spanning Tree, allowing for greater network availability.
- C. REP supports Industrial Ethernet protocols better because it moves the packets faster.
- D. Running dual cables from access switches to an aggregation switch can have a much higher cost on the plant floor than in the Enterprise and running a ring protocol like REP provides resiliency at a lower cost.
- E. Industrial protocols can be negatively impacted by the number of nodes the Ethernet frame traverses, REP provides a topology with no more than 3 nodes for any data path.

Answer: B, D

Question: 7

Which five are characteristics that describe Cisco Industrial switches? (Choose five)

- A. Din rail mount
- B. 19 inch rack mount
- C. Fanless
- D. Fans
- E. Swappable SD flash card
- F. Alarm relay
- G. -5°C to 45°C operating environment
- H. ProfiNET conformance class C compliance

Answer: A, B, C, E, F

Question: 8

Which selection is a reason why IGMP snooping should be configured on a switched network?

- A. IGMP snooping populates the snooping table with the results of DHCP requests and can be used by Dynamic ARP Inspection to block IP spoofing attacks at Layer-2.
- B. IGMP snooping verifies the source IP address of every IPv4 packet to ensure that it hasn't been originated from a port different than its return path.
- C. IGMP snooping is used to filter ping requests and results to avoid overflowing the MAC address table of the switch.
- D. IGMP snooping allows a Layer-2 switch to limit the transmission of multicast frames to only the ports that have members of the relevant IGMP group.

Answer: D

Thank You for trying 200-601 PDF Demo

To Buy Latest 200-601 Full Version Download visit link below

<https://www.certkillers.net/Exam/200-601>

Start Your 200-601 Preparation

[Limited Time Offer] Use Coupon “CKNET” for Further discount on your purchase. Test your 200-601 preparation with actual exam questions.

<https://www.certkillers.net>